

- I Up to a volume of 12ft³** (e.g. max. 36" x 24" x 24") with:
 $\geq 1/4"$ steel on the body
 $\geq 1/2"$ steel on the door
- II Up to a volume of 29ft³** (e.g. max. 44" x 34" x 34") with:
 $\geq 1/2"$ steel on the body and door
- III Up to a volume of 39ft³** (e.g. max. 52" x 36" x 36") with:
 $\geq 1"$ steel on the body and door
- IV For composite safes:**
Up to a volume of 42ft³ (e.g. max. 72" x 35" x 29") with:
 composite material on the body and door

Requirements when using one GM550EUL seismic detector fig. 27

When using one GM550EUL on **night deposits, ATM's or burglar resistant steel safes**, the following guidelines must be followed.

The detector may be mounted anywhere on the inside or outside of the body or door, but it is recommended that the detector be mounted near the hinges. If the linear surface inches or volumes listed below are exceeded, additional detector(s) are required. One of the following two sets of conditions must be met:

- I** The safe must be a minimum of $1/4"$ (6mm) steel on the body and $1/2"$ (12mm) steel on the door with a maximum safe size not to exceed a volume of 12ft³ (0.34m³), example: 36" x 24" x 24" (914mm x 609mm x 609mm). The detector must be mounted within a central location so that at no time is there any point more than 48 linear surface inches (1219mm) from the detector. Use a minimum sensitivity of C at 100% or 200% response time.
- II** The safe must be a minimum of $1/2"$ (12mm) steel on the body and door with a maximum safe size not to exceed a volume of 29ft³ (0.8m³), example: 44" x 34" x 34" (1117mm x 864mm x 864mm). The detector must be mounted within a central location so that at no time is there any point more than 71 linear surface inches (1800mm) from the detector. Use as minimum sensitivity of D at 100% or 200% response time.
- III** The safe must be a minimum of 1" (25.4mm) steel on the body and door with a maximum safe size not to exceed a volume of 39ft³ (1.1m³), example: 52" x 36" x 36" (1320mm x 914mm x 914mm). The detector must be mounted within a central location so that at no time is there any point more than 72 linear surface inches (1828mm) from the detector. Use as minimum sensitivity of D at 100% or 200% response time.
- IV Composite safes, only UL listed burglary resistant safes:**
 The safe must be of composite material (steel and concrete) with a maximum safe size not to exceed a volume of 42ft³ (1.2m³), example: 72" x 35" x 29" (1827mm x 888mm x 736mm). The detector must be mounted within a central location so that at no time is there any point more than 101 linear surface inches (2563mm) from the detector. Use as minimum sensitivity of D at 100% or 200% response time.

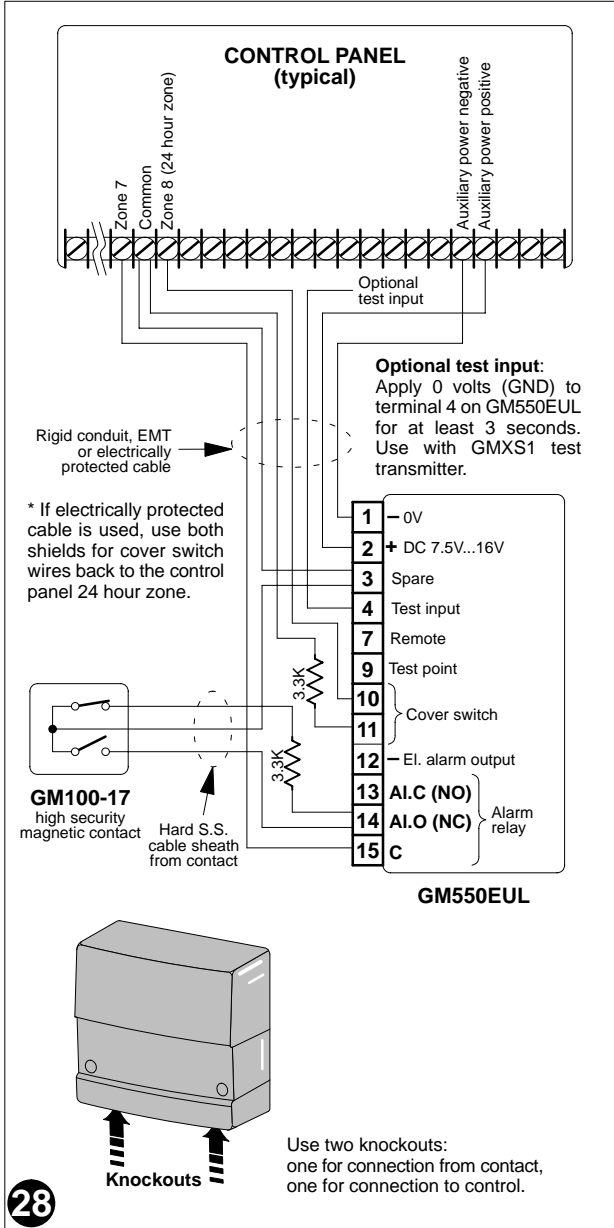

Typical UL complete mercantile safe installation (UL681) fig. 28

1. Power supply must have at least 4 hours of standby power for Mercantile or 72 hours for Bank Alarm Systems.
2. UL Listed Safe Contact:
 - 1) Use high security contact for use on safes and vaults, such as the CADDX GM-100-17, which comes with a 3 ft. attached Hard S.S. Cable Sheath (see diagram). Mount on the outside of the safe, OR
 - 2) Use an ordinary-use UL634 alarm contact and mount on inside of safe.
3. A smoke or heat sensor is **not** required.
4. Use rigid conduit, EMT, or electrically protected cable for connection to control.
5. Fire resistant safes must have a minimum of $1/4"$ (6mm) steel jacket on body and $1/2"$ (12mm) steel jacket on door. Refer to dimensions listed in A) and B) above for spacing requirements.
6. Test procedure activation using method a) OR b) preferred.
 - a) Simulate an attack signal next to the detector by scratching lightly on the safe with a screwdriver or by hitting safe with a hammer for a minimum of 30 seconds.
 - b) Attach the GMXS1 test transmitter to the GM550EUL plug in connection. Activate test by applying 0 volts to terminal 4 for at least 3 seconds. This can be accomplished through different methods:
 - 1) Use a normally opened switch to apply power supply negative to terminal 4, OR
 - 2) Use a UL listed control panel that will provide a 0 volt output to terminal 4 upon testing. This could effectively test the GM550EUL each time the system is tested.
7. Test procedure indication of alarm activation:
 When using test procedure a) or b) above, look to control panel zone indication for test verification.

CADDX-CADDI CONTROLS INC.
1420 N. Main Street
Gladewater, Texas 75647
USA
PHONE (903) 845 6941
FAX (903) 845 6811